

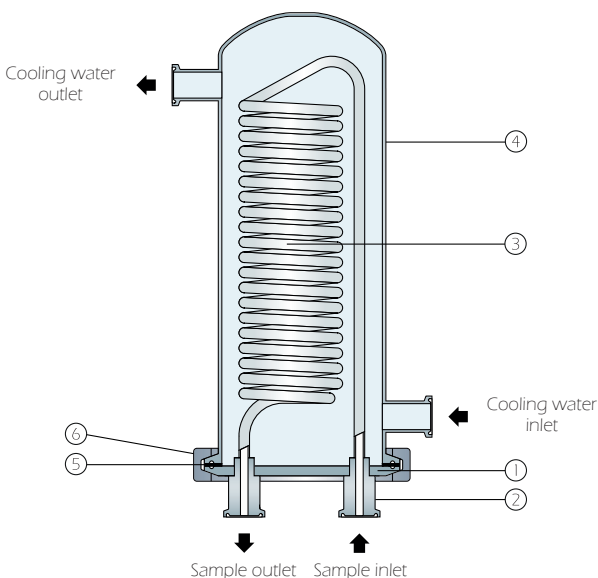

Designed for environments where the cooling water supply may lead to fouling of the coil, the HSC50 can be disassembled for cleaning. The orientation of the sample connections also makes the HSC50 suitable for continuous in-line cooling applications such as conductivity monitoring in high purity systems.



Pressure Rating

Coil and shell - up to 10 barg



Temperature Rating

Coil - 175°C
Shell - 100°C



Connections

Sample medium -
25mm clamp to suit 1/2 "ASME BPE, DIN and ISO
Cooling water -
25mm clamp to suit 3/4 "ASME BPE, DIN and ISO



Performance

Heat transfer area - 0.08m²
Coil volume - 160ml
Typical performance - 10kg/h condensate at 30°C
from steam at 3 barg with 0.1 l/s cooling water at
20°C rising to 40°C



Surface Finish

Wetted surfaces - 0.5 microns Ra*
External surfaces - Satin polish finish
(*Coil formed from tube with an internal electropolished finish of 0.25 microns Ra)



Options

Electropolished finish - all wetted surfaces
Steam throttling valve (HSV60)
Sample outlet hose adaptor
Steam and cooling water hoses



Available Certification

CofC Certificate of Conformity

MTR's Material Certification

ADI Certified 'Animal Derived Ingredient' free

Part	Description
1	Base plate 316L stainless steel
2	Sample medium fittings 316L stainless steel
3	Coil 316L stainless steel
4	Body 316L stainless steel
5	Seal EPDM
6	Clamp 304 stainless steel

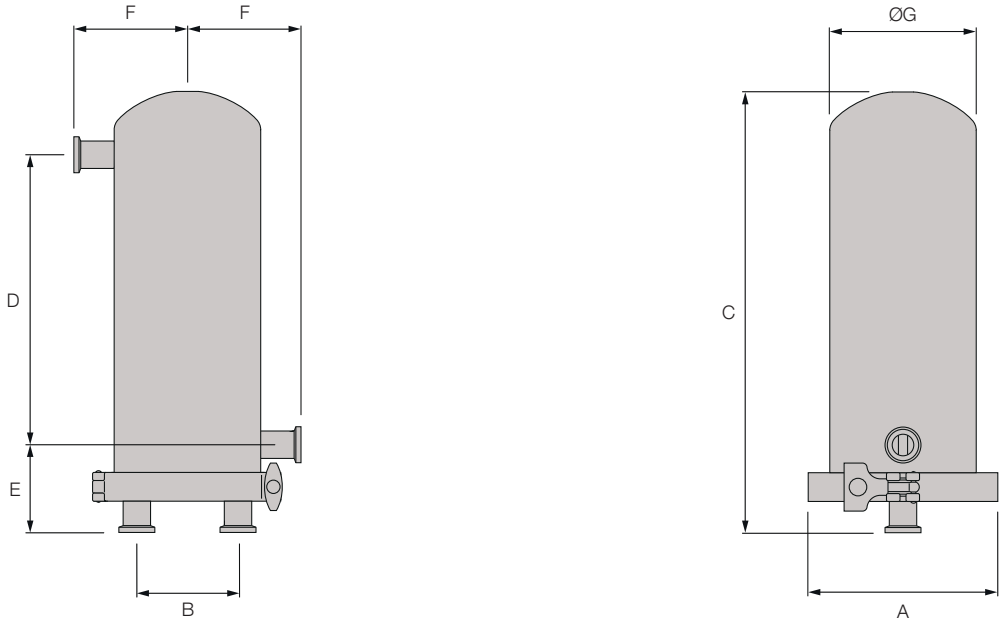
HSC50							
							
Dimensions (mm)							Weight (kg)
A	B	C	D	E	F	ØG	
135	70	305	200	63	75	102	4.5

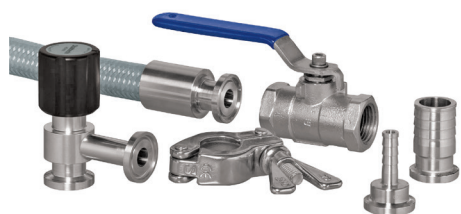

+ Accessories

HSV60 sample valve - a steam rated valve suitable for both isolation and throttling of the steam sample

Sample hose adaptor kit - 316L stainless steel hose adaptor with 8.5mm barb which connects directly to the sample medium outlet using a standard clamp and seal

PTFE lined sample hose - PTFE lined hose with stainless steel outer braid and silicone protective cover. Available with 1/2" ASME BPE clamp end fittings to any length required

Cooling water hose - reinforced PVC hose with 3/4" ASME BPE clamp end fittings to any length required



Packaging

Individually capped and boxed



Service Parts

Body seal - part 5

Staitech

Staitech Ltd · PO Box 152 · Stroud
Glos · GL6 8YT · UK

Tel: +44 (0) 1543 882736 · Fax: +44 (0) 1543 882744

E-mail: sales@staitech.com · Web: www.staitech.com

Specifications subject to change without notice. HSC50-TB - 04/18