

HSG03 SIGHT GLASS

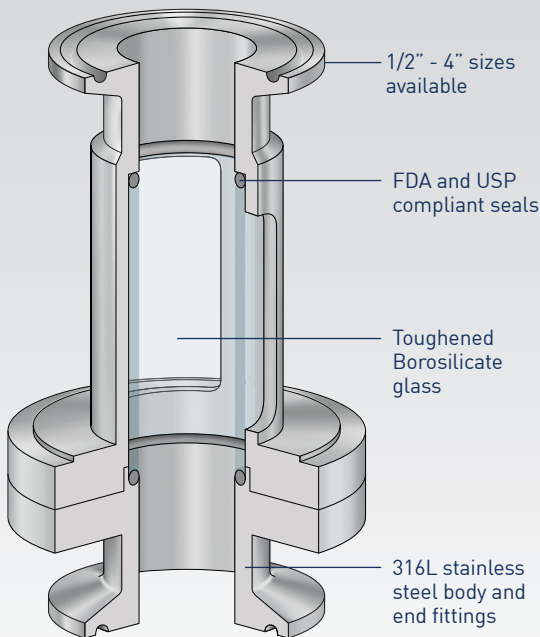

HSG03

The HSG03 range of sight glasses are designed for use in high purity applications where through window visibility is required. The bore of the glass and end fittings match that of the corresponding tubing size thus eliminating the possibility of fluid retention, even when units are installed horizontally. The unique bolted body design ensures that any torsional forces exerted by the piping systems are transferred through the machined body of the unit therefore protecting the glass against possible damage. An optional Polycarbonate knock shield is also available for improved security.

P Pressure Rating	Up to 10 barg
T Temperature Rating	150°C with EPDM seals 200°C with Viton or Silicone seals 200°C with FEP-Silicone seals 135°C when knock shield fitted
Connections	1/2" - 4" ASME BPE clamp 1/2" - 2" ASME BPE weld end DN8 - DN50 DIN and ISO clamp DN8 - DN50 DIN and ISO weld end
Wetted Parts	Body - 316L stainless steel Glass - Borosilicate
Seal Material	EPDM, Viton, Silicone or FEP-Silicone
Surface Finish	Wetted surfaces - 0.5 microns Ra (SF1) External surfaces - 0.8 microns Ra
Options	Polycarbonate knock shield Low ferrite stainless steel (WN1.4435), C22 and other alloys Perlast seals (High performance PTFE) Backlight Electropolished finish (SF4)
C Certification	Certificate of conformity Material certification FDA Elastomer compliance certificate USP Elastomer compliance certificate Certified 'Animal Derived Ingredient' free
★ Features	<ul style="list-style-type: none"> • Full bore design for optimal drainability • Suitable for piping systems where torsional loads exist • Two large viewing apertures for unobstructed monitoring of the flow media • Optional knock shield for increased glass protection • Metal-metal assembly joint for controlled seal compression • All material fully certified • Easy replacement of glass and seals

HSG03 SIGHT GLASS

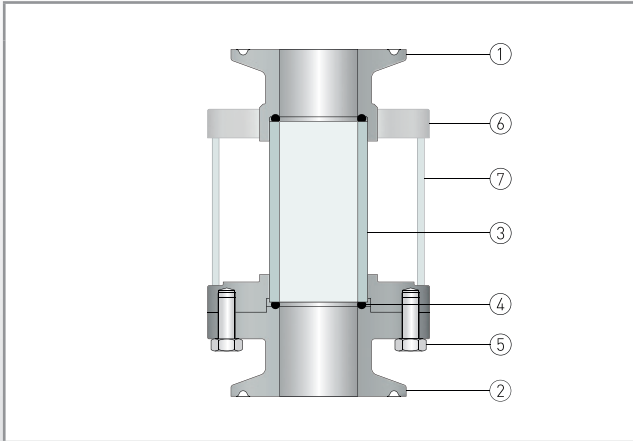

Part	Description
1	Body 316L stainless steel
2	End fittings 316L stainless steel
3	Glass* Borosilicate
4	Seals** EPDM, Viton, Silicone or FEP-Silicone
5	Body screws Stainless steel
6	Support ring*** 316L stainless steel
7	Knock shield*** Polycarbonate

* Glass meets the requirements of ASTM E 438, Type I, Class A as well as ISO 3585:1998.

** All seals are FDA and USP compliant. EPDM and FEP-Silicone are USP 121°C compliant.

*** Knock shield is optional.

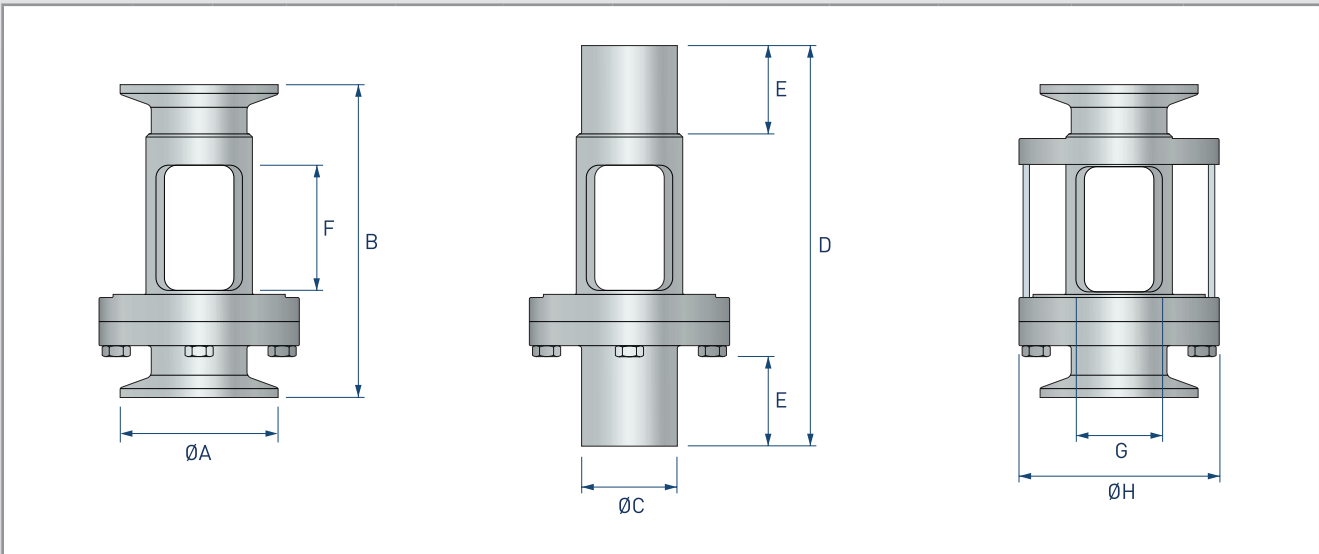

Size ASME BPE	Size Clamp	Size Weld	Dimensions (mm)							Weight (kg)	
			ØA	B	ØC	D	E	F	G Viewing Area*	ØH	
1/2"	✓	✓	25	90	12.7	124	28	40	120°	44	0.1
3/4"	✓	✓	25	90	19.05	128	28	40	120°	44	0.1
1"	✓	✓	50.5	100	25.4	128	28	40	120°	64	0.45
1-1/2"	✓	✓	50.5	100	38.1	130	28	40	120°	64	0.7
2"	✓	✓	64	100	50.8	140	28	40	120°	84	1.0
2-1/2"	✓	-	77.5	100	-	-	-	40	120°	100	1.8
3"	✓	-	91	100	-	-	-	40	120°	109	2.5
4"	✓	-	119	100	-	-	-	40	120°	150	3.6

*Sight glasses have 2 windows at 180° separation

Service Parts - Seal kit (4) 2 seals per set, glass (3) and knock shield lens (7)

Backlight option



HSG03 ASME BPE connections - ordering code							
Product		Size		Connections		Seals	Options
	-				-		
Without knock shield		1/2"	050	Clamp	C	FDA compliant	Electropolishing EP
HSG03		3/4"	075	Weld	W	Silicone - red SR	
With knock shield		1"	100			FDA & USP Class VI compliant	
HSG03KS		1-1/2"	150			EPDM - black EBKU	
		2"	200			Viton - black VBKU	
		2-1/2"	250	Clamp	C	Silicone - white SW	
		3"	300			FEP-Silicone FEPS	
		4"	400			Perlast PLW	

Example

HSG03	-	050C		-	EBKU		-	EP
--------------	----------	-------------	--	----------	-------------	--	----------	-----------

Specification text

Staitech HSG03 sight glass manufactured in 316L stainless steel with Borosilicate glass and EPDM FDA and USP Class VI compliant seals. 1/2" ASME BPE clamp connections. Wetted surfaces finished to 0.5 microns Ra. External surfaces finished to 0.8 microns Ra. (HSG03-050C-EBKU). For electropolished finish add suffix '-EP' (HSG03-050C-EBKU-EP).

Staitech HSG03 sight glass manufactured in 316L stainless steel with Borosilicate glass and EPDM FDA and USP Class VI compliant seals. Fitted with Polycarbonate knock shield. 1/2" ASME BPE clamp connections. Wetted surfaces finished to 0.5 microns Ra. External surfaces finished to 0.8 microns Ra. (HSG03KS-050C-EBKU). For electropolished finish add suffix '-EP' (HSG03KS-050C-EBKU-EP).

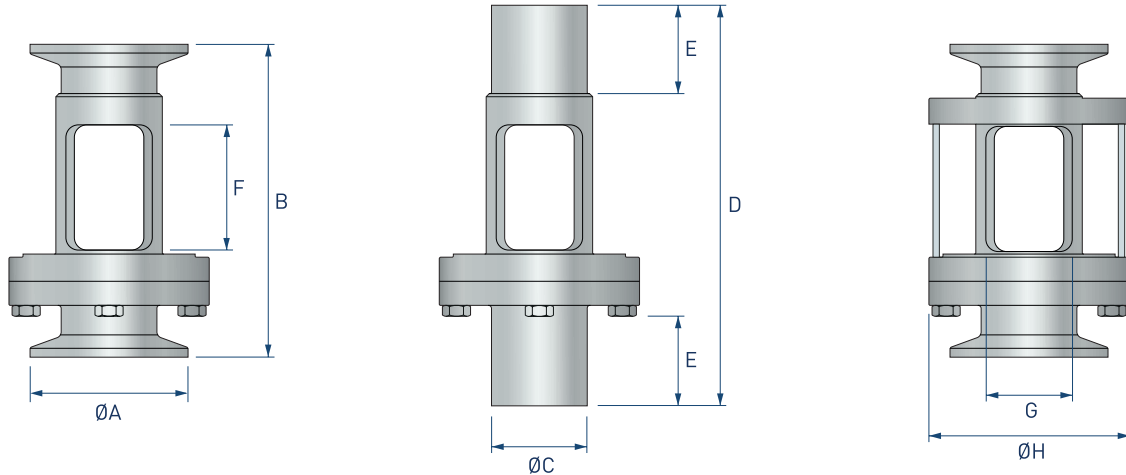

Size DIN	Dimensions (mm)								Weight (kg)
	ØA	B	ØC	D	E	F	G* Viewing area	ØH**	
DN8	25 or 34	90	10.0	124	28	40	120°	44	0.1
DN10	25 or 34	90	12.0	124	28	40	120°	44	0.1
	25 or 34	90	13.0	124	28	40	120°	44	0.1
DN15	25 or 34	90	18.0	128	28	40	120°	64	0.4
	25 or 34	90	19.0	128	28	40	120°	64	0.4
DN20	25 or 34	90	23.0	128	28	40	120°	64	0.45
DN25	50.5	100	28.0	128	28	40	120°	64	0.5
	50.5	100	29.0	128	28	40	120°	64	0.5
DN32	50.5	100	35.0	130	28	40	120°	64	0.7
DN40	50.5	100	41.0	140	28	40	120°	84	1.0
DN50	64	100	53.0	140	28	40	120°	100	1.8

Size ISO	Dimensions (mm)								Weight (kg)
	ØA	B	ØC	D	E	F	G* Viewing area	ØH**	
DN8	25	90	13.4	124	28	40	120°	44	0.1
DN10	25	90	17.2	124	28	40	120°	44	0.1
DN15	34	90	21.3	124	28	40	120°	44	0.1
	50.5	90	21.3	124	28	40	120°	44	0.1
DN20	50.5	100	26.9	128	28	40	120°	64	0.45
DN25	50.5	100	33.7	128	28	40	120°	64	0.6
DN32	64	100	42.4	130	28	40	120°	64	0.7
DN40	64	100	48.3	140	28	40	120°	84	1.0
DN50	77.5	100	60.3	140	28	40	120°	100	1.8

*Sight glasses have 2 windows at 180° separation

** Dimension E only applies when knock shield is fitted

HSG03 DIN connections - ordering code										
Product	Connections		Size		Seals		Options			
Without knock shield HSG03	Clamp	C	DIN DN8	34.0 - 8.0	FDA compliant Silicone - red	SR	Electropolishing	EP		
With knock shield HSG03KS				25.0 - 8.0						
			DIN DN10	34.0 - 10.0					FDA & USP Class VI compliant	
				25.0 - 10.0						
			DIN DN15	34.0 - 15.0					EPDM - black	EBKU
				25.0 - 15.0					Viton - black	VBKU
			DIN DN15	25.0 - 16.0					Silicone - white	SW
				34.0 - 16.0					FEP-Silicone	FEPS
			DIN DN20	34.0 - 20.0					Perlast	PLW
				50.5 - 25.0						
			DIN DN25	50.5 - 26.0						
				50.5 - 26.0						
			DIN DN32	50.5 - 32.0						
				50.5 - 32.0						
	DIN DN40	50.5 - 40.0								
		50.5 - 40.0								
	DIN DN50	64.0 - 50.0								
		64.0 - 50.0								
Without knock shield HSG03	Weld	W	ISO DN8	10.0 - 8.0						
With knock shield HSG03KS				12.0 - 10.0						
			ISO DN10	13.0 - 10.0						
				18.0 - 15.0						
			ISO DN15	19.0 - 16.0						
				19.0 - 16.0						
			ISO DN20	23.0 - 20.0						
				28.0 - 25.0						
			ISO DN32	29.0 - 26.0						
				29.0 - 26.0						
	ISO DN32	35.0 - 32.0								
		35.0 - 32.0								
	ISO DN40	41.0 - 38.0								
		41.0 - 38.0								
	ISO DN50	50.3 - 50.0								
		50.3 - 50.0								
Example										
HSG03	-	C	-	34.0 - 8.0	-	EBKU	-	EP		
Specification text										
<p>Staitech HSG03 sight glass manufactured in 316L stainless steel with Borosilicate glass and EPDM FDA and USP Class VI compliant seals. DIN DN8 34mm clamp connections. Wetted surfaces finished to 0.5 microns Ra. External surfaces finished to 0.8 microns Ra. (HSG03-C-34.0-8.0-EBKU). For electropolished finish add suffix '-EP' (HSG03-C-34.0-8.0-EBKU-EP).</p> <p>Staitech HSG03 sight glass manufactured in 316L stainless steel with Borosilicate glass and EPDM FDA and USP Class VI compliant seals. Fitted with Polycarbonate knock shield. DIN DN8 34mm clamp connections. Wetted surfaces finished to 0.5 microns Ra. External surfaces finished to 0.8 microns Ra. (HSG03KS-C-34.0-8.0-EBKU). For electropolished finish add suffix '-EP' (HSG03KS-C-34.0-8.0-EBKU-EP).</p>										

HSG03 ISO connections - ordering code									
Product	Connections		Size		Seals		Options		
Without knock shield HSG03	Clamp	C	ISO DN8	25.0 - 10.3	FDA compliant	Silicone - red	SR	Electropolishing	EP
With knock shield HSG03KS			ISO DN10	25.0 - 14.0					
			ISO DN15	34.0 - 18.1					
			ISO DN15	50.5 - 18.1					
			ISO DN20	50.5 - 23.7					
			ISO DN25	50.5 - 29.7					
			ISO DN32	64.0 - 38.4					
			ISO DN40	64.0 - 44.3					
			ISO DN50	77.5 - 56.3	FDA & USP Class VI compliant				
Without knock shield HSG03	Weld	W	ISO DN8	13.4 - 10.3	EPDM - black	EBKU			
With knock shield HSG03KS			ISO DN10	17.2 - 14.0	Viton - black	VBKU			
			ISO DN15	21.3 - 18.1	Silicone - white	SW			
			ISO DN20	26.9 - 23.7	FEP-Silicone	FEPS			
			ISO DN25	33.7 - 29.7	Perlast	PLW			
			ISO DN32	42.4 - 38.4					
			ISO DN40	48.3 - 44.3					
			ISO DN50	60.3 - 56.3					
Example									
HSG03	-	C	-	34.0 - 18.1	-	EBKU	-	EP	
Specification text									
<p>Staitech HSG03 sight glass manufactured in 316L stainless steel with Borosilicate glass and EPDM FDA and USP Class VI compliant seals. ISO DN15 34mm clamp connections. Wetted surfaces finished to 0.5 microns Ra. External surfaces finished to 0.8 microns Ra. (HSG03-C-34.0-18.1-EBKU). For electropolished finish add suffix '-EP' (HSG03-C-34.0-18.1-EBKU-EP).</p> <p>Staitech HSG03 sight glass manufactured in 316L stainless steel with Borosilicate glass and EPDM FDA and USP Class VI compliant seals. Fitted with Polycarbonate knock shield. ISO DN15 34mm clamp connections. Wetted surfaces finished to 0.5 microns Ra. External surfaces finished to 0.8 microns Ra. (HSG03KS-C-34.0-18.1-EBKU). For electropolished finish add suffix '-EP' (HSG03KS-C-34.0-18.1-EBKU-EP).</p>									