

VIP* If you purchased your MK95 valve, or any stem repair component for this valve after 9/17/2018 - please see ****VIP**** assembly instruction change on page 2, top-right, section 3.

Staitech

Manufactured by STERIFLOW / Web: www.steriflowvalve.com
Distributed in the UK by:
Staitech Ltd / Unit 6 / Hope Mill Lane / Stroud / GL5 2SH / UK
+44 (0) 1453 882736 / sales@staitech.com / www.staitech.com

I & M Mark 95 Series

Installation & Maintenance Instructions for MK95 Sanitary Back Pressure Regulators

Warning: Steriflow Sanitary Pressure Regulators must only be used, installed and repaired in accordance with these Installation & Maintenance Instructions. Observe all applicable public and company codes and regulations. In the event of leakage or other malfunction, call a qualified service person; continued operation may cause system failure or a general hazard. Before servicing any valve, disconnect, shut off, or bypass all pressurized fluid. Before disassembling a valve, be sure to release all spring tension.

Please read these instructions carefully!

Your Steriflow product will provide you with long, trouble-free service if it is correctly installed and maintained. Spending a few minutes now reading these instructions can save hours of trouble and downtime later. When making repairs, use only genuine Jordan Valve parts, available for immediate shipment from the factory.

Ideal Installation

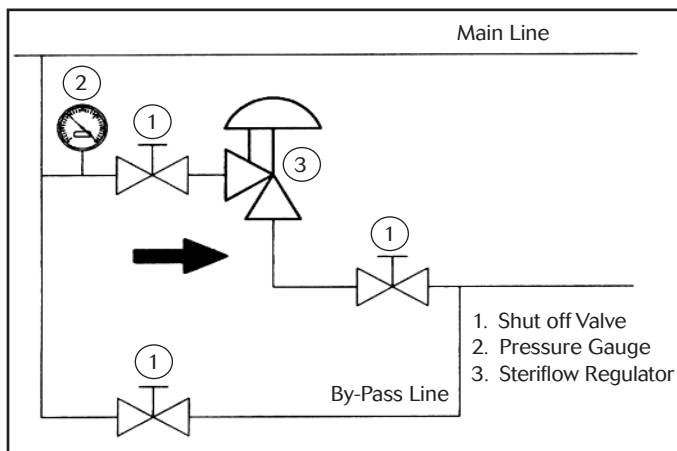

1. The valve is designed for sanitary service and it is assumed that it will be installed into a clean system. Under these conditions, special considerations to protect the valve such as providing line strainers at the valve inlet are not necessary.
2. The regulator is to be installed with the inlet horizontal and the outlet pointed down. This will provide the best drainage inside the valve. These restrictions apply only for drainage considerations; the valve will function in any position. Contact factory for other possible orientations.
3. Steam regulators are best located at the highest point in the piping with the take-off out of the top of the steam header. This will minimize the possibility of water in the regulator.
4. For best control, 3' 0" straight sections of pipe should be installed on either side of the regulator.
5. Use caution in tightening commercial sanitary fit-

tings. Over-tightening can cause the gasket to extrude into the flow passage.

6. If possible, install a relief valve downstream from the regulator. Set at about 30% above the control point of the regulator.
7. Operate the regulator within its pressure and temperature rating as stamped on the valve nameplate.

Start-Up

1. Slowly open the inlet shutoff valve and slowly turn the adjusting screw until the desired inlet pressure is shown on the inlet pressure gauge, without discharging fluid.
2. To change the controlled pressure, turn the adjusting screw clockwise to increase the pressure, or counterclockwise to decrease the pressure.
3. Once the desired setpoint is obtained, run the thumblock down until it reaches the top of the spring housing. Then run the hex jam nut down to the top of the thumblock and lock the two together. This will effectively keep the adjusting screw from turning due to vibration, etc. This is useful during the cleaning cycle (see section on Clean-In-Place/ Steam-In-Place.)

Warning: Never substitute an longer length adjusting screw. The valve may fail to open and personal injury or property damage could occur.

Maintenance

Caution: Make certain that there is no pressure in the valve before loosening any fittings or joints. The following steps are recommended:

1. Close the inlet shutoff valve.
2. Turn the adjusting screw counterclockwise until there is no pressure on the spring, allowing any trapped pressure to release downstream.
3. Allow pressure to bleed off through the downstream piping. Do not attempt to reverse the flow through the valve by bleeding pressure from the upstream side of the valve.

PROTECT VALVES WITH LINE STRAINERS

4. When the pressure gauges indicate that all pressure has been removed from the system, close the outlet shutoff valve. The valve may be removed from the line and serviced.

Note: refer to the drawing at the end of this document for description and proper orientation of parts.

Clean-In-Place

To allow the valve to open for cleaning, back off the adjusting screw to remove all range spring load. Maintain the position of the thumb-lock and hex jam nut on the stem so that the adjusting screw can be returned to its normal position to maintain the set point. After cleaning return the adjusting screw back to the original set point by using the thumb-lock and an indicator.

NOTE: 2" Valves do not use a thumb-lock, but instead use two jam nuts.

Disassembling the Valve

1. Follow the instructions under the "Maintenance" section to remove the valve from line.
2. Back off the adjusting screw to remove the load from the range spring.
3. Remove the spring housing by removing the hex head cap screws.
4. Remove the spring and spring guide.
5. Remove the cylinder by removing the hex jam nut along with lockwasher on valves with a Stainless Steel diaphragm. This will allow you to remove the CIP spring and adapter.
6. Remove the spacer, upper diaphragm plate, diaphragm gasket (only included on 1/2" - 1" models with a 3-8 psi (0,2-0,5 bar) spring range) and diaphragm from the stem. Remove the lower diaphragm plate and o-ring where applicable.

CAUTION: If the valve is equipped with a metal diaphragm, the edges are very sharp. Exercise caution to avoid lacerations.

7. Remove the stem and the o-ring (on 3/4" and 1" valves with a metal diaphragm only) from the body.

Preparing Valve For Assembly

1. All parts should be cleaned and examined. Damaged parts should be replaced.
2. Do not lubricate o-rings.

NOTE: For all assembly lubrication requirements, Steriflow uses Bostik NEVER_SEEZ, White Food Grade with PTFE, Cat. No. NSWT-14 (improved version without mineral oils). Never use lubricant on any component below the diaphragm.

3. For soft-seated valves:

****VIP** Use the NEW LOCTITE INSTRUCTIONS below for soft seated valves that meet the following conditions:**

- If you are working on a valve that was purchased after 9/17/2018.
- If you are installing a repair kit for a valve that was purchased after 9/17/2018, and a part number in that repair kit has a model suffix of -SLFLK, -SFLK, or -SLK.

NEW LOCTITE INSTRUCTIONS for valves or parts that meet the above conditions:
Loctite is no longer required for wetted stem component assembly. It can still be used, but its use will make future stem disassembly more difficult. For valves or parts that don't meet the above conditions use the following instructions:

Clean threads on the stem and on retainer with Loctite primer 7649. Follow Loctite's instructions for primer and sealant. Install new soft seat onto retainer (or onto stem when applicable on low flow versions). Apply Loctite Sealant 243 to threads and thread the retainer onto the stem. Tighten until the screw threads run out. Allow to cure.

Assembling the Valve

1. Install o-ring into the groove in the body (not required on valves with elastomer diaphragm).
2. Install o-ring into the groove in the lower diaphragm plate. Install lower diaphragm plate onto stem (not required on valves with elastomer diaphragm).
3. Install O-Ring onto stem.
4. Install diaphragm onto stem.
- 4a. Install diaphragm gasket (only included on 1/2" - 1" models with a 3-8 psi (0,2 -0,5 bar) spring range).
5. Install upper diaphragm plate onto stem.
6. Install spacer onto stem.
7. Install stem into body. Center diaphragm onto body. Note: when using the ultra-thin Jorlon diaphragm, gasket P/N 31203-* is to be centered over the diaphragm prior to placing the adaptor onto the body.
8. Install adapter onto body. The adapter should engage the pilot diameter on the body.
9. Install the cylinder onto the stem.
10. Install lockwasher onto stem (not required on valves with elastomer diaphragm).
11. Apply Loctite Sealant 243 with Primer 7649 (following Loctite's instructions) to the Stem threads. Install Hex Jam nut onto stem and hand tighten. Lightly tighten with a wrench. If valve has a Jorlon™, or elastomer diaphragm, tighten only 1/4 turn

- more with wrench.
12. Install spring into the cylinder.
Note: If valve came with a Spring Spacer, (or if you receive a Spring kit that includes a Spring Spacer), install it into the cylinder, then install the spring.
 13. Install spring guide onto the spring.
 14. Lubricate the O.D. surfaces of the cylinder and install the spring housing.
 15. Attach the nameplate to the body with one of the hex head cap screws.
 16. Install hex jam nut and thumb-lock (or second hex jam nut) onto the adjusting screw and lubricate the thread on the adjusting screw. Thread adjusting screw into the spring housing only about four threads.
 17. Secure spring housing to the body. Hand-tighten all of the hex head cap screws. Place a light spring load on the stem by turning the adjusting screw clockwise. This will center the plug on its seat. Torque* hex head cap screws to 200 in/lbs. (17 ft/lbs.).
* Torque cap screws in star pattern to insure an even compressive load. This is especially critical for Ultrathin Jorlon diaphragm with 3-8 psi spring. Not doing so, will damage the diaphragm.

number is located on the valve identification tag. If the serial number is not available, the parts needed for your valve might be determined using the following information: Model Number, Valve Body Size, Seat Material and Cv Rating, Spring Range and Set Point, Trim Material, Part Name - Number and Quantity.

NOTE: Any parts ordered without a valve serial number that are found to be incorrect are subject to up to a minimum 25% restock charge when returned.

Troubleshooting

If You Experience Erratic Control:

- Regulator may be oversized. Oversizing causes cycling and hunting, and reduces the rangeability of the valve – make certain that your valve has been correctly sized according to your application conditions.
- Valve seat may be defective - replace stem and/or body.
- Valve plug may not be moving freely – inspect the cylinder and spring housing.

Upstream Pressure Build-up or Inability to Maintain Regulated Pressure:

- Inspect for jamming between cylinder and spring housing.
- Diaphragm may have failed – replace if necessary.
- Piping may be blocked or undersized.
- Range spring may be set too high or may be broken – inspect and reset or replace as necessary.
- The valve may be undersized for required flow – make certain that the valve has been sized correctly.

Ordering Spare Parts

Use only genuine Steriflow Valve parts to keep your valve in good working order. So that we can supply the parts, which were designed for your valve, we must know exactly which product you are using. The only guarantee to getting the correct replacement parts is to provide your Steriflow Representative with the valve serial number. This

Illustration and Parts List (3/4" - 3")

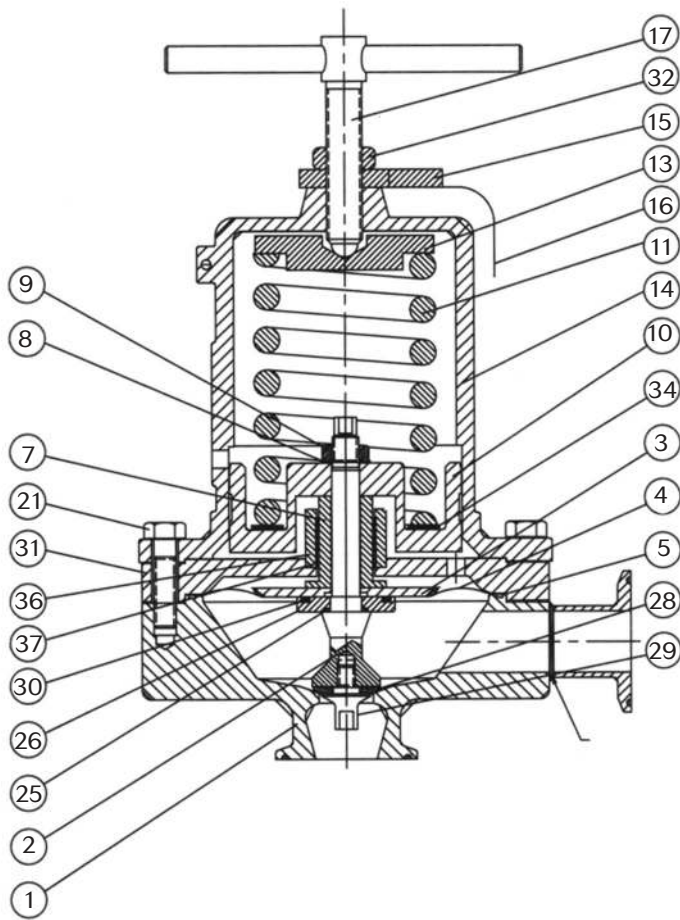

Item	Description	Qty.
1	Body S/A	1
2	Stem	1
3	Upper Diaphragm Plate	1
4	Diaphragm & Gasket	1
5	O-Ring	1
7	Spacer	1
8	Lockwasher	1
9	Hex Jam Nut	1
10	Cylinder	1
11	Range Spring	1
13	Spring Guide	1
14	Spring Housing	1
15	Thumblock	1
16	Name Plate	1
17	Adjusting Screw S/A	1
21	HHCS	8
25	O-Ring	1
26	Lower Diaphragm Plate	1
28	Soft Seat	1
29	Soft Seat Retainer	1
30	O-Ring	1
31	Adapter	1
32	Hex Jam Nut	1
34	Spring Spacer	1
36	Gland	1
37	Bushing	1

Warning: Steriflow Sanitary Pressure Regulators must only be used, installed and repaired in accordance with these Installation & Maintenance Instructions. Observe all applicable public and company codes and regulations. In the event of leakage or other malfunction, call a qualified service person; continued operation may cause system failure or a general hazard. Before servicing any valve, disconnect, shut off, or bypass all pressurized fluid. Before disassembling a valve, be sure to release all spring tension.

How to Operate

Set Point Adjustment

Turn the Adjusting Nut (2) clockwise to increase the pressure set point, and counter clockwise to decrease the set point.

Lift Lever operation

To open the valve (lift the valve plug off the orifice) to drain upstream process or to enable free draining for CIP, Rinse, or SIP, raise the Lift Lever (1) so that the lever is pointing up. Note that the cam on the end of the lift lever will keep it in the up position.

To resume pressure regulation (after process draining, CIP, Rinse or SIP), lower the Lift Lever (1) to the position shown in the illustration below.

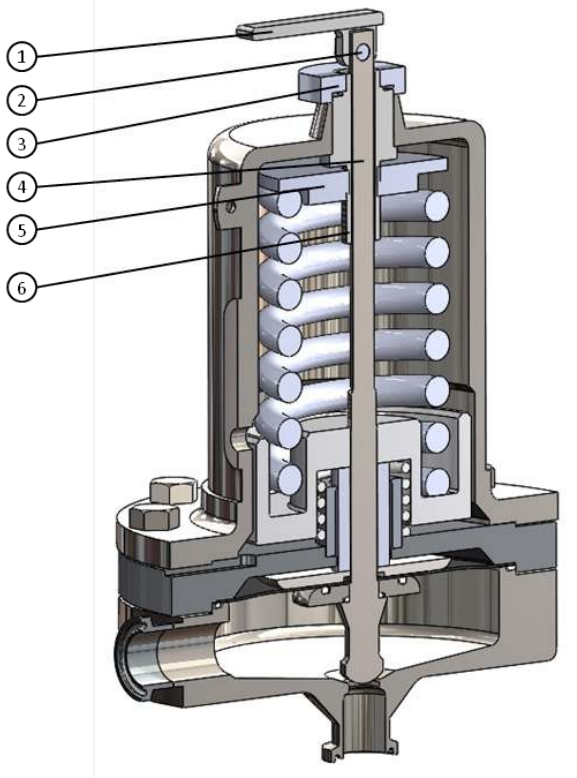

Assembling the Valve

1. Install the o-ring into the groove in the body (not required on valves with elastomer diaphragm).
2. Install o-ring into the groove in the lower diaphragm plate. Install lower diaphragm plate onto stem (not required on valves with elastomer diaphragm).
3. Install o-ring onto stem/plug (4).
4. Install diaphragm onto stem stem/plug (4).
5. Install upper diaphragm plate onto stem/plug (4).
6. Install spacer onto stem/plug (4).
7. Install stem/plug (4) into body. Center diaphragm onto body. Note: when using the ultra-thin Jorlon diaphragm, gasket P/N 31203-* is to be centered over the diaphragm prior to placing the adapter plate onto the body.
8. Install adapter plate onto body. The adapter plate should engage the pilot diameter of the body.
9. Install the cylinder onto the stem/plug (4).
10. Install the lockwasher onto the stem/plug (4) (not required on valves with elastomer diaphragm).
11. Apply Loctite Sealant 243 with Primer 7649 (following Loctite's instructions) to the stem/plug(4) threads. Install hex jam nut onto stem/plug (4) and hand-tighten. Lightly tighten with a wrench. If valve has a Jorlon™, or elastomer diaphragm, tighten only 1/4 turn more than with wrench.
12. Install spring into the cylinder.
Note: If valve came with a Spring Spacer, (or if you receive a Spring kit that includes a Spring Spacer), install it into the cylinder, then install the spring.

Item	Description	Qty.
1	Lift Lever	1
2	Lever Pin	1
3	Adjusting Nut	1
4	Stem/Plug	1
5	Spring Guide	1
6	Adjusting Screw	1

Assembling the Valve, Cont.

13. Lubricate the adjusting screw (6).
14. Thread the spring guide (5) onto the adjusting screw (6).
15. Install the spring guide (5) onto the stem/plug (4) and rest part on top of the spring.
16. Lubricate the O.D. surfaces of the cylinder and install the spring housing ensuring the top of the adjusting screw passes through the spring housing and that all components align vertically.
17. Attach the nameplate to the body with one of the hex head cap screws.
18. Secure spring housing to the body. Hand-tighten all of the hex head cap screws. Ensuring you maintain alignment of the diaphragm with the stem/plug (4) with the body. This will center the plug on its seat. Torque* hex head cap screws to 200 in.lbs. (17 ft/lbs.).
* Torque cap screws in star pattern to ensure an even compressive load. This is especially critical for Ultra-thin Jorlon diaphragm with 3-8 psi spring. Not doing so, will damage the diaphragm.
19. Place the adjusting nut (3) onto the top of the adjusting screw (6) sticking through the spring housing.
20. Align the stem/plug lift lever (1) and place lever pin (2) through the lift lever (1) and the very top of stem/plug (4). Secure lever pin (2) with a clevis pin.