

****VIP**** If you purchased your MK96AA Valve, or any stem repair component for this valve after 9/17/2018 - please see ****VIP**** assembly instruction change on page 4, middle-left, section 3.

Staitech

Manufactured by STERIFLOW / Web: www.steriflowvalve.com
Distributed in the UK by:
Staitech Ltd / Unit 6 / Hope Mill Lane / Stroud / GL5 2SH / UK
+44 (0) 1453 882736 / sales@staitech.com / www.staitech.com

I & M Mark 96AA Series

Installation & Maintenance Instructions for MK96AA Sanitary Pressure Regulators

Warning: Steriflow Sanitary Pressure Regulators must only be used, installed and repaired in accordance with these Installation & Maintenance Instructions. Observe all applicable public and company codes and regulations. In the event of leakage or other malfunction, call a qualified service person; continued operation may cause system failure or a general hazard. Before servicing any valve, disconnect, shut off, or bypass all pressurized fluid. Before disassembling a valve, be sure to release all spring tension.

Please read these instructions carefully!

Your Steriflow product will provide you with long, trouble-free service if it is correctly installed and maintained. Spending a few minutes now reading these instructions can save hours of trouble and downtime later. When making repairs, use only genuine Steriflow Valve parts, available for immediate shipment from the factory.

Introduction

The Mark 96AA is a manually adjustable sanitary pressure regulating valve (PRV) with a remote operation feature. Users can manually adjust the outlet pressure set point within the valves spring range, or can opt to operate the valve entirely by air loading the sealed spring via a remote, adjustable air regulator, or I/P.

Traditional sanitary PRV's are normally operated with only a manual adjustment knob that adds or subtracts tension to a spring that sits on a platform on top of a diaphragm whose opposite side is connected to a stem and valve plug. The opposite (process side) of the diaphragm is exposed to the outlet side of the valve (downstream pressure). Increasing the tension on the spring moves the diaphragm and stem in the opening direction, conversely increasing the downstream pressure. Stated another way, increasing the spring tension, increases the valve's outlet pressure set point; and decreasing the spring tension, decreases the set point pressure.

Sanitary PRV's are typically installed several feet above grade and are usually not easily accessible because of the installation height, or obstructions, or because of their location in a clean room manufacturing suite. Typical installation or adjustment involves the time of at least one technician to manually adjust the regulator for system operating pressure changes (balancing pressures during initial system commissioning, or for changing valve stem position during operation for CIP, for example). The MK96AA was invented to solve these regulator access and manpower problems. It uses a spring and T-handle for manual operation, and has an air inlet connection on the spring housing to allow for either partial or fully automated remote operation via a remote,

adjustable air pressure regulator or I/P.

Partial automation involves manually adjusting the outlet pressure set point to the systems lowest pressure setting (SIP for example). Additional upward adjustments in set point are made by remotely increasing the air pressure on top of the diaphragm so that the regulators output is appropriate for other system functions like CIP.

If configured for full automation, the regulator is manually set to it's lowest possible spring setting (not system pressure setpoint). All system pressure settings are set, and changed by a remote air regulator or an I/P driven by the process DCS or PLC.

Ideal Installation

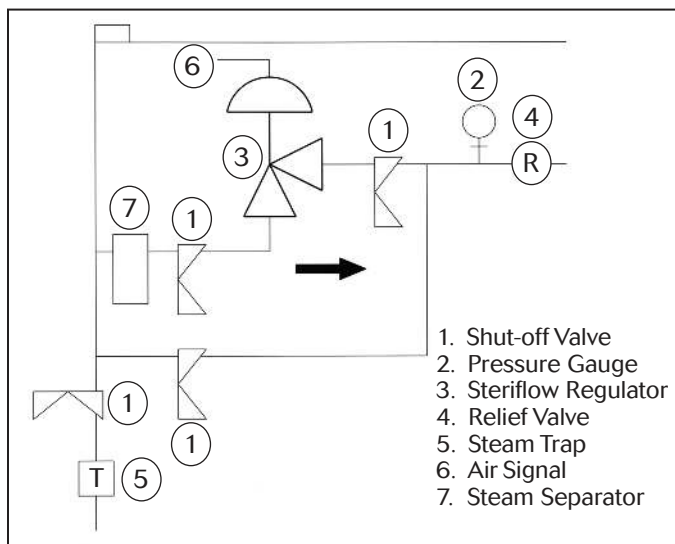

Refer to MK96AA Illustrated Parts List on Page 5.

1. The valve is designed for sanitary service and it is assumed that it will be installed into a clean tubing system. Under these conditions, special considerations to protect the valve such as providing line strainers at the valve inlet are not necessary.
2. The regulator should be installed with the inlet (bottom of valve) vertical and the outlet horizontal. This orientation allows unhindered drainage (zero holdup). Please note the valve will function in any

- position.
3. Steam regulators are best located at the highest point in the piping with the take-off out of the top of steam header, or vertical riser on a distribution leg. This will minimize the possibility of retained water in the regulators flow stream.
 4. For best control, 3' 0" straight sections of pipe should be installed on either side of the regulator to insure a non-turbulent flow profile.
 5. In order to accurately set a pressure regulator, a gauge pressure instrument should be installed at the regulator outlet. The ideal installation is downstream on the vena contracta, at least three pipe diameters downstream of the regulator. However, if space or cost is a concern, a gauge pressure instrument may be directly mounted on an optional regulator outlet gauge port.
 6. If possible, install a relief valve downstream from the regulator. Set at about 30% above the control point of the regulator.
 7. If you are in gas or vapor service, and your control setpoint is 25% or less than the inlet pressure, you should expand your outlet piping by one pipe diameter for optimal performance.
 8. Use caution in tightening commercial sanitary fittings. Over-tightening can cause the gasket to extrude into the flow passage.
 9. Operate the MK96AA within its pressure and temperature rating as stamped on the valve nameplate.
 10. **If using an air regulator with your MK96AA:**
Safety Note: Only select tubing, tube fittings and other airline components with a design pressure allowing their safe use at pressures up to your air systems maximum pressure rating. Make sure the air regulator or I/P you select will not have any chance to overload the MK96AA diaphragm. The maximum air loading pressure for your MK96AA can be determined by subtracting your maximum manual set point pressure from your minimum spring set point pressure from the chart below.

MK96AA Connection	Maximum Allowable Pressure Setpoint
3/4" - 1"	135 psi (9,3 bar)
1-1/2"	100 psi (6,9 bar)
2" - 3"	80 psi (5,5 bar)

Example:

- a) If your manual spring set point for a 3/4" MK96AA is 15 psi, the maximum amount of air pressure that you can load the spring housing with is 120 psi (=135 – 15).
- b) If you are setting up your 3/4" MK96AA with 2 – 8 psi spring, for fully automatic mode, you will manually adjust the valve to it's minimum spring rate, or 2 psi. In this scenario, the maximum amount of air pressure that you can load into the spring housing

is 133 psi (=135 – 2).

Select an air regulator with an appropriate outlet air pressure range, one that is a self-relieving type, and preferably one that has an outlet gauge. Install a 1/4" tube fitting into the 1/4" FNPT air inlet (37) on the side of the MK96AA. Connect an appropriate length of 1/4" tubing and connect the other end to a tube fitting installed in the outlet of the air pressure regulator installed at an accessible grade location. Install a shut off valve upstream of the air regulator in the inlet side tubing.

11. **If using an I/P with your MK96AA:** *Make sure the I/P selected has the proper NEMA or IS rating classification for the installation area, or install in a cabinet with the proper classification. See also safety notes under # 10.* Connect the tubing with the same components, and in the same manner as described above in 10. Connect the wiring to the nearest I/P terminal in the manner following the manufacturer's instructions, local electrical code and local best practice. Follow the installation, operation, maintenance and safety instructions that come with your I/P.
12. **Safety Note:** Test the Integrity of the airlines you just installed. Double check all tube fittings and connections to make sure all are tight, and secure enough to handle a pressure up to your air system's maximum pressure rating. Lastly pressurize the lines to the maximum pressure that they can see.

Set-Up and Start-Up

Safety Note: The following procedures will effect process pressure. Take appropriate action to insure process and personnel safety.

1. Make sure all MK96AA process connections are secure for their rated pressure, and that all installation instructions have been followed.
2. Fully open the process line block valve downstream of the regulator.
3. Slowly open the block valve installed immediately upstream of the regulator.
4. Slowly open and close the downstream block valve several times; this will stroke the valve and confirm satisfactory operation.
5. **Manual operation for minimum set point, with air augmentation for higher settings:**
 - a. **To manually set the MK96AA range spring to the minimum pressure set point follow the next procedure:** *Safety Note: Make sure the spring housing is not pressurized at this point. Shut off the air supply to the regulator or I/P.*
 - i. Loosen the nut (15) on the adjusting screw (17). With both process line block valves open, slowly increase the MK96AA

- spring tension by turning the adjusting screw in the clockwise direction (counter-clockwise to decrease the set point). Monitor the gauge pressure downstream of the MK96AA (outlet side). Readjust the adjusting screw (17) until you are satisfied that the downstream outlet pressure is correctly set to the process systems minimum pressure set point. When satisfied, tighten the nut (15) on the adjusting screw, compressing the Teflon seal (15) to seal the stem and lock its position. Do not overtighten.
- ii. Open the shut off valve on the inlet side of the air regulator or I/P. Adjust either device following the manufacturer's instructions and load 15 psi air to the spring housing (17).
 - iii. Make sure the Teflon seal (15) is not leaking air. If it is, compress the Teflon seal by tightening the nut (15) 1/4 turn, or slowly until the air stops leaking.
 - iv. Continue this process of increasing the pressure and checking/tightening the seal, up to you maximum loading pressure.
- b. **To elevate the MK96AA outlet pressure to another higher setting, or to fully open the valve using the air augment feature:**
- i. **Using a remote mounted air pressure regulator:** Note: the MK96AA inlet block valve must be open to perform the following procedure. Slowly increase the air pressure into the spring housing by adjusting the air regulator knob (following adjustment instructions in the regulator's installation manual) until the process pressure downstream of the MK96AA reaches the desired value. If desired, mark the air regulator handle position with a Sharpie or other marking device, or record the pressure.
 - ii. **Using an I/P:** Most DCS or PLC HMI systems allow for manual override of output current (4-20 Ma output). If that is not possible, the I/P wiring can be disconnected, and a process loop calibrator can be used to artificially drive the I/P to varied outputs. Configure the I/P following the manufacturer's instructions. To adjust the MK96AA setpoint, slowly increase the spring housing pressure by driving the I/P's Ma input to a value that produces the desired MK96AA outlet pressure. Record the Ma set point value for the PLC or DCS programmer in the proper document, or in the control system information database.
6. **Fully Automated Operation using Air Augment Features:**
 - a. **To manually set the MK96AA range spring to the minimum spring rate for full automated operation follow the next procedure:** **Safety Note: make sure the spring housing is not pressurized at this point. Shut off the air supply to the regulator or I/P.**
 - i. Loosen the nut (15) on the adjusting screw (17) and set the regulator to it's minimum spring rate by turning the MK96AA adjusting screw counter-clockwise to reduce pressure, clockwise to increase pressure until pressure is equal to the minimum spring setting. (Check your valve specifications, or the tag on the valve to determine the range spring purchased with your valve. The minimum spring rate is the smallest number in the range spring specification. For example, a 1" MK96AA with a 5-25 psi spring, has a 5 psi minimum spring setting). Check the pressure reading downstream and verify that the pressure setting is at the spring's minimum rate. If so, tighten the Teflon seal nut (15) following instructions in 6.a.ii-v above.
 - b. **Setting up a Remote mounted air pressure regulator for all set points operation:** See 5.b. and 5.b.i above.
 - c. **Setting up an I/P for fully automated operation:** See 5.b. and 5.b.ii above.

Maintenance

Caution: Make certain that there is no pressure in the valve before loosening any fittings or joints. The following steps are recommended:

1. Close the air supply valve to the MK96AA air regulator or I/P. Carefully vent any air in the spring housing (14).
2. Close the block valve upstream of the regulator inlet.
3. Allow pressure to bleed off through downstream piping. Do not attempt to reverse the flow through the valve by bleeding pressure from the regulator outlet to the inlet side.
4. When the upstream and downstream pressure gauges indicate that all pressure has been removed from the system, remove the air load or disconnect the I/P following the devices maintenance manual. The valve can now be serviced.

Note: Refer to the Mark 96AA illustrated parts list on page 5 for description and proper orientation of parts.

Disassembling the Valve

3/4" thru 3" Mark 96AA

1. Insure that the valve is not pressurized by following the Caution at the beginning of the Maintenance Section.
2. Loosen the Teflon Seal Nut (15).
3. Back off the adjusting screw (17) to remove the load from the range spring (11). Make sure all spring tension is removed before proceeding.
4. Remove the spring housing (14) by removing the hex head cap screws (21).
5. Remove the spring guide (13) and range spring (11).
6. Remove the hex jam nut (9) from the stem (2).
7. Remove the cylinder (10), adapter plate o-rings (5) and adapter plate (31).
8. Remove the spacer (7), upper diaphragm plate (3), diaphragm gasket (only included on 1/2" - 1" models with a 3-8 psi (0,2-0,5 bar) spring range), and diaphragm (4) from the stem (2). Remove the lower diaphragm plate (26) and o-rings (25), (30).
9. Remove the stem (2).

Preparing the Valve for Assembly

1. All parts should be cleaned and examined. Damaged parts should be replaced.
2. O-ring should be lubricated. They may be lubricated with any lubricant that is compatible with both your process and the o-ring material. EPDM o-rings must not be exposed to mineral oil as it will cause them to swell and make them difficult to install.
3. For soft seated valves:

****VIP** Use the NEW LOCTITE INSTRUCTIONS below for soft seated valves that meet the following conditions:**

- If you are working on a valve that was purchased after 9/17/2018.
- If you are installing a repair kit for a valve that was purchased after 9/17/2018, and a part number in that repair kit has a model suffix of -SLFLK, -SFLK, or -SLK.

NEW LOCTITE INSTRUCTIONS for valves or parts that meet the above conditions:

Loctite is no longer required for wetted stem component assembly. It can still be used, but its use will make future stem disassembly more difficult.

For valves or parts that don't meet the above conditions use the following instructions:

Clean threads on the stem (2) and on retainer (29) with Loctite primer 7649, following Loctite's instructions. Install new soft seat (28) onto retainer (or onto stem when applicable on low flow versions). Apply Loctite Sealant 243 (following Loctite's

instructions) to threads and thread the retainer (29) onto the stem (2). Tighten until the screw threads run out. Allow to cure.

Assembling the Valve

3/4" thru 3" Mark 96AA

1. Install stem (2) into the body (1).
2. Lubricate o-ring (5) and install to the shoulder on the stem in the adapter plate (31).
3. Lubricate o-ring (25) and install into the groove on the stem (2). Install lower diaphragm plate (26) onto the stem (2). Lubricate o-ring (30) and install into the groove in the lower diaphragm plate (26).
4. Install diaphragm (4) onto stem (2).
- 4a) Install diaphragm gasket (only included on 1/2" - 1" models with a 3-8 psi (0,2-0,5 bar) spring range).
5. Install upper diaphragm plate (3) onto stem (2).
6. Install spacer (7) onto stem (2).
7. Center diaphragm (4) onto body (1). *Note: when using the ultra-thin Jorlon diaphragm gasket P/N 31203-* is to be centered over the diaphragm prior to placing the adapter onto the body.* Install adapter plate (31) onto body (1). The adapter plate (31) should engage the pilot diameter on the body (1).
8. Install the cylinder (10) onto the stem (2).
9. Install hex jam nut (9) onto stem (2) and tighten only 1/4 turn. Apply Loctite Primer 7649 and Sealant 243 (following Loctite's instructions to threads to lock the joint).
10. Install range spring (11) into the cylinder (10).
11. Install spring guide (13) onto the range spring (11).
12. Secure the spring housing (14) to the body (1). Hand tighten the hex head screws (21).
13. Install Teflon Seal and nut (15) onto the adjusting screw (17).
14. Lubricate threads on the adjusting screw (17) and thread into the spring housing (14). The adjusting screw (17) should engage the hole on the spring guide (13) inside the spring housing (14). Turn the handle clockwise to place a light preload on the spring (11) to hold the parts in place.
15. Torque hex head screws (21) to 200 in-pounds.

Troubleshooting

If You Experience Erratic Control:

- Oversizing causes cycling or hunting, and reduces the rangeability of the valve. Make certain that your sizing is correct.
- Steam traps may require maintenance.
- Safety valve may be defective.
- Valve seat in Mark 96AA may be defective – replace stem (2) and/or body (1).
- Valve plug in Mark 96AA may not be moving freely. Inspect bushing (36) and replace if required.

Downstream Pressure Build-Up:

- Valve seat in Mark 96AA may be defective – replace stem (2) and/or body (1).
- Valve plug in Mark 96AA may not be moving freely. Inspect bushing (36) and replace if required.
- Diaphragm in Mark 96AA may have failed; replace diaphragm if necessary.
- If Mark 96AA is equipped with hard seat, consider replacing with soft seat for tighter shutoff.

Cannot Maintain Regulated Pressure:

- Piping may be blocked or inadequately sized.
- Inlet pressure may be set too low.
- Spring may be broken or set too low; check setting; replace spring if broken.
- Valve may be undersized for required flow; make certain that your sizing is correct.
- System demand exceeds pump or boiler capacity.

Mark 96AA Illustration and Parts List

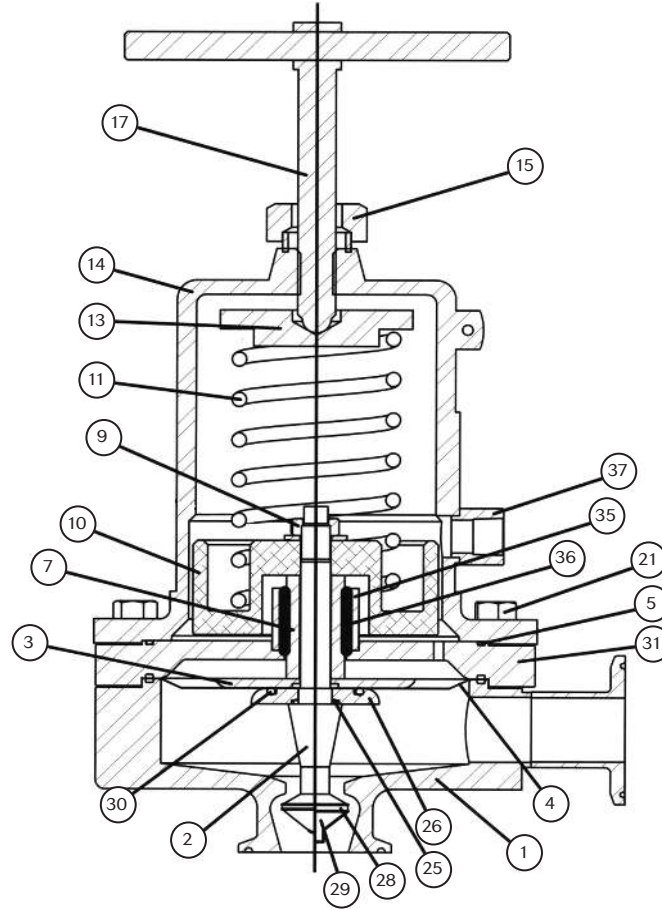

Item	Description	Qty.	Item	Description	Qty.
1	Body S/A	1	17	Adjusting Screw S/A	1
2	Stem	1	21	HHCS, 3/4" - 1"	8
3	Upper Diaphragm Plate	1		HHCS, 1-1/2" & 2"	12
4	Diaphragm	1	25	O-Ring	1
5	O-Ring	1	26	Lower Diaphragm Plate	1
7	Spacer	1	28	Optional Soft Seat	1
9	Hex Jam Nut	1	29	Soft Seat Retainer	1
10	Cylinder	1	30	O-Ring	1
11	Range Spring	1	31	Adapter	1
13	Spring Guide	1	35	Gland	1
14	Spring Housing	1	36	Bushing	1
15	Teflon Seal & Nut	1	37	1/4" FNPT Air Inlet	1

All parts shaded in gray are included in the Mark 96AA retrofit kit.

Fastener Torque		
Item	Description	Torque
9	Hex Jam Nut	150 - 200 in.-lbs.
21	Hex Head Cap Screw (HHCS)	200 in.-lbs.



3170 Wasson Road • Cincinnati, OH 45209 USA
Phone 513-533-5600 • Fax 513-871-0105
steriflow@richardsind.com • www.steriflowvalve.com

I & M Mark 96AA Retrofit Kit

Instructions for Removal of MK96 Components and Field Replacement with MK96AA Retrofit Kit Components

Warning: Steriflow Sanitary Pressure Regulators must only be used, installed and repaired in accordance with these Installation & Maintenance Instructions. Observe all applicable public and company codes and regulations. In the event of leakage or other malfunction, call a qualified service person; continued operation may cause system failure or a general hazard. Before servicing any valve, disconnect, shut off, or bypass all pressurized fluid. Before disassembling a valve, be sure to release all spring tension.

Please read these instructions carefully!

Your Steriflow product will provide you with long, trouble-free service if it is correctly installed and maintained. Spending a few minutes now reading these instructions can save hours of trouble and downtime later. When making repairs, use only genuine Jordan Valve parts, available for immediate shipment from the factory.

Maintenance

Caution: Make certain that there is no pressure in the valve before loosening any fittings or joints. The following steps are recommended.

1. Close the inlet shutoff valve.
2. Allow pressure to bleed off through downstream piping. Do not attempt to reverse the flow through the valve by bleeding pressure from the inlet side.
3. When the pressure gauges indicate that all pressure has been removed from the system, the valve may be service.

Disassembling MK96

Refer to Mark 96 Illustrated Parts List on page 8.

3/4" thru 3" Mark 96

1. Insure that the valve is not pressurized by following the Caution at the beginning of the Maintenance Section.
2. When disassembling, lay all parts on flat surface in an organized manner.
3. Back off the adjusting screw (17) to remove the load from the range spring (11). Make sure all spring tension is removed before proceeding.
4. Remove the spring housing (14) by removing the Hex head cap screws (21).
5. Remove the spring guide (13) and spring (11).
6. Remove the hex jam nut (9) and lockwasher (8) if so equipped.
7. Remove the cylinder (10) and adapter (31).
8. Remove the spacer (7), upper diaphragm plate (3),

diaphragm gasket (only included on 1/2" - 1" models with a 3-8 psi (0,2–0,5 bar) spring range), and diaphragm (4) from the stem (2). **Caution: if the valve is equipped with a metal diaphragm, the edges are very sharp.** Exercise care to avoid lacerations. Remove the lower diaphragm plate (26) and o-rings (25), (30) where applicable.

9. Remove the stem (2) and o-ring (5)
10. Discard diaphragms (4) and body o-ring (5). Note: MK96AA retrofit valves and retrofit kits use a Jorlon (FDA, USP Class VI) diaphragm, which is provided with your retrofit kit.

Only the body (1) and Hex Head Cap Screws (21) will be reused for the retrofit kit. Inspect all other parts removed from the MK96 body and either discard, or place all acceptable parts in tagged, plastic bags in your spare parts inventory for future use.

Preparing MK96 Valve Body for MK96AA Retrofit Kit Assembly

Refer to MK96AA Illustrated Parts List on page 5.

1. Inspect body (1), inside and out, for any nicks or scratches, and any deformation around the seat. Make sure inside of body, particularly the seat and diaphragm sealing area are clean, and that entire valve is suitable for reuse in a sterile environment.
2. Inspect Hex Head Cap Screws (21), and make sure all or suitable for reuse. *Note: There are 4 extra Hex Head Cap Screws in a plastic bag included with your retrofit kit.*
3. Remove your MK96AA kit from the packing carton and set on a flat work surface with enough room to lay all of the parts out in an organized manner.
4. With the Retrofit Kit laying and stable, hold the Kit by the spring housing (14), and turn the adjusting screw (17) counter-clockwise to remove all spring tension.
5. Hold the Retrofit Kit so that the stem is facing toward you. Cut the plastic zip ties securing the spring housing (14) to the adaptor (31), and remove. While holding the end of the stem, gently

- remove the spring housing (14) with adjusting screw (17), from the rest of the components (stem, diaphragm and adaptor assembly).
- 6. Remove the hex jam nut (9).
- 7. Remove the stem (2) and it's o-ring (25), lower diaphragm plate (26) with o-ring (30), diaphragm (4), and upper diaphragm plate (3) - as a single assembly and place as such on your work space.
- 8. Remove the stem (2) from the subassembly and set it next to the rest of the parts in an organized fashion. *Note: make sure the stem o-ring (25) stays with the stem in its intended position.*

- groove on top of the adapter (31).
- 11. Carefully install the spring housing (14) assembly (with adjusting screw (17)) over the spring guide (13) and range spring (11).
- 12. Align spring housing (14) thru holes with adapter (31) thru holes, and the body (1) tapped holes.
- 13. Insert Hex head cap screws (21) and hand tighten. *Note: if you need extra Hex head cap screws, there are 4 of them included in the Retrofit Kit.*
- 14. Turn the adjusting screw (17) clockwise until you can feel it engage the spring guide (13). Turn on more full turn.
- 15. Torque Hex Head cap screws to 200 in-pounds.

Assembling the MK96AA Retrofit Kit to the MK96 Body

Note: If you have purchased a true MK96AA Retrofit Kit and not just specific parts, everything except the MK96 body (1) and Hex Head Cap Screws (21) will be replaced. All parts in the kit will be lubricated and loosely assembled.

Refer to the MK96AA Illustrated parts list on page 5.

3/4" thru 3" Mark 96 Body with Mark 96AA Retrofit Kit

1. While holding the MK96 body (1), install the Retrofit Kit stem (2) (threaded end first) through the valve body (1) inlet.
2. Hold the stem in the body straight, and slide the lower diaphragm plate (26) with its o-ring (30) over the stem's threaded end, flat side down. *Note: Make sure the stem o-ring (25) is still in its proper position.*
3. Install the diaphragm (4) onto the stem (2). *Note: only Jorlon diaphragms can be used with the Mark 96AA. No diaphragm/body o-ring is needed when using a standard thickness Jorlon diaphragm. When using the ultra-thin Jorlon diaphragm, gasket P/N 31203-* is to be centered over the diaphragm prior to placing the adapter onto the body.*
- 3a) Install diaphragm gasket (only included on 1/2" - 1" models with a 3-8 psi (0,2 -0,5 bar) spring range).
4. Install the upper diaphragm plate (3) onto the stem (2).
5. Install adapter (31)/gland (35)/bushing (36)/spacer (7) sub assembly on to stem (2). Align adapter thru bolt holes with tapped holes in the body.
6. Install cylinder (10) onto stem (2), onto the adapter sub assembly.
7. Install Hex jam nut (9) over the stem (2) threaded end and hand tighten. Using a torque wrench, tighten to 150 - 200 in-pounds.
8. Install range spring (11) into cylinder (10).
9. Install spring guide (13) onto the top of the range spring (11).
10. Install adapter/spring housing o-ring (5) into the

Mark 96 Illustration and Parts List

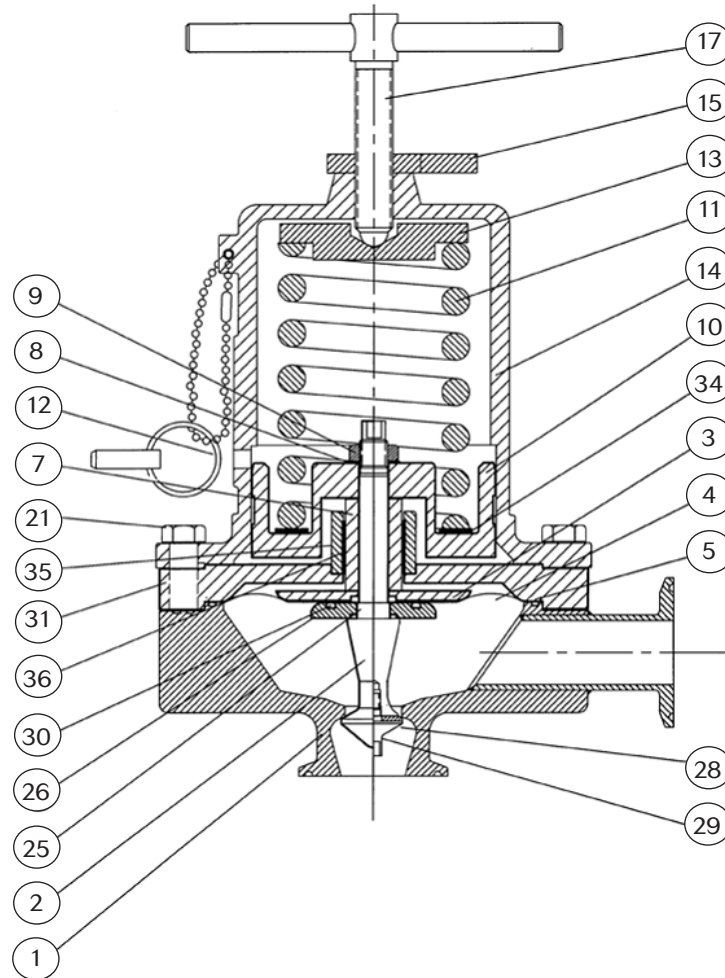

Item	Description	Qty.	Item	Description	Qty.
1	Body S/A	1	15	Thumb Lock or Hex Jam Nut	1
2	Stem	1	17	Adjusting Screw S/A	1
3	Upper Diaphragm Plate	1	21	HHCS, 3/4" - 1"	8
4	Diaphragm	1		HHCS, 1-1/2" & 2"	12
5	O-Ring	1	25	O-Ring	1
7	Spacer	1	26	Lower Diaphragm Plate	1
8	Lockwasher	1	28	Optional Soft Seat	1
9	Hex Jam Nut	1	29	Soft Seat Retainer	1
10	Cylinder	1	30	O-Ring	1
11	Range Spring	1	31	Adapter	1
12	CIP/SIP Pin S/A	1	34	Stack-Up Ring	1
13	Spring Guide	1	35	Gland	1
14	Spring Housing	1	36	Bushing	1

Note: Items 5 and 8 not required when using a Jorlon diaphragm.